



RL-9714

SHIELDED SMD POWER INDUCTOR

DESCRIPTION

- SMD Power Inductor

ENVIRONMENTAL DATA

- Storage temperature range: -55°C to +130°C
- Operating temperature range: -40°C to +130°C

PACKAGING INFORMATION

- Packaging information: pg. 492

FEATURES & APPLICATIONS

- Maximize performance in the smallest possible package size with a low profile
- Excellent as a power inductor used in notebook computers and other electronic equipment requiring compact and low-loss inductors
- Available in 4 values with inductance ratings from 2.7 μH to 6.8 μH and currents up to 1.70 A

Verify operation with sample in actual circuit. Order samples at www.rencousa.com.

MECHANICAL DIMENSIONS

U.S. Standard (mm)

PART NUMBER	A (MAX.)	B (MAX.)	C (MAX.)	D (TYP.)	E (TYP.)	F (TYP.)	G (TYP.)
RL-9714	0.204 (5.20)	0.208 (5.30)	0.060 (1.50)	0.101 (2.70)	0.040 (1.10)	0.080 (2.00)	0.059 (1.50)

PART NUMBER	PART WEIGHT	H (REF.)	I (REF.)	J (REF.)	K (REF.)	L (REF.)	M (REF.)
RL-9714	1.0g (0.04oz)	0.212 (5.40)	0.094 (2.40)	0.098 (2.50)	0.212 (5.40)	0.212 (5.40)	0.055 (1.40)

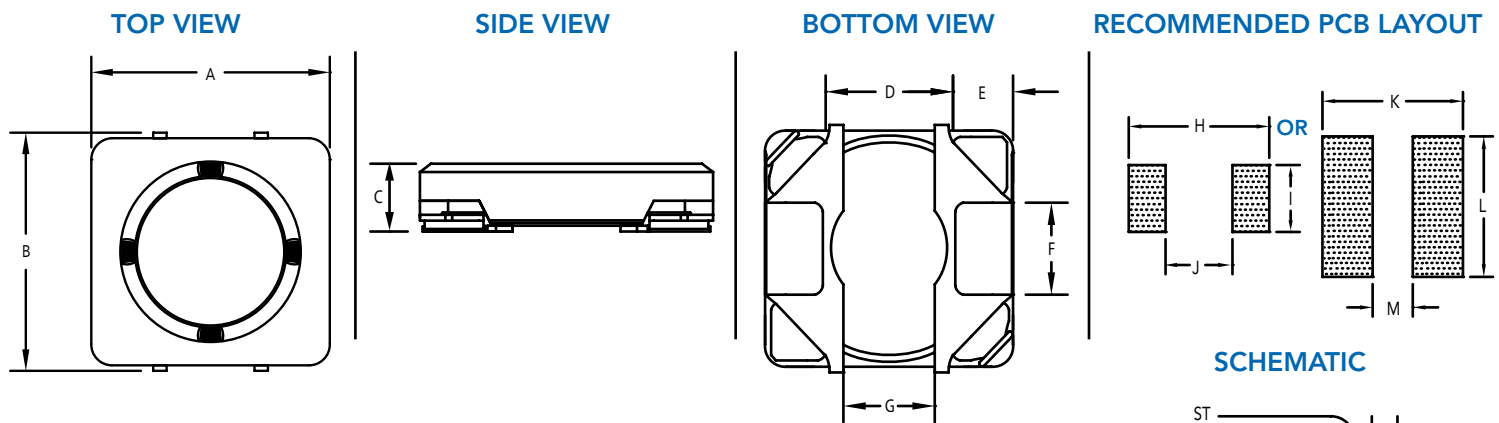

SURFACE MOUNTS



RENCO ELECTRONICS INC.

595 International Place, Rockledge, FL 32955-4200 USA • www.rencousa.com • ISO 9001 Certified
 Toll Free Engineering Hot Line: 800.645.5828 • P: 321.637.1000 • F: 321.637.1600



RL-9714

Renco Part No. RL-9714	Inductance (μ H)	DCR Max. (Ohms)	Isat (A)	Irms (A)
RL-9714-2R7N	2.7 \pm 30%	0.067	1.70	2.00
RL-9714-3R3N	3.3 \pm 30%	0.076	1.50	1.80
RL-9714-4R7M	4.7 \pm 20%	0.094	1.20	1.60
RL-9714-6R8M	6.8 \pm 20%	0.110	1.00	1.50

NOTES:

1. Isat - DC CURRENT THAT WILL CAUSE INDUCTANCE TO DROP BY 30%
2. Irms - CURRENT THAT CAUSES THE TEMPERATURE TO RISE APPROX. 40°C ABOVE AMBIENT OF 25°C
3. ELECTRICAL SPECIFICATIONS MEASURED AT 25°C
4. RESISTANCE TO SOLDER HEAT: 260°C FOR 10 SECONDS
5. INDUCTANCE TESTED AT 100 kHz, 0.1Vrms



RENCO ELECTRONICS INC.

595 International Place, Rockledge, FL 32955-4200 USA • www.rencousa.com • ISO 9001 Certified
Toll Free Engineering Hot Line: 800.645.5828 • P: 321.637.1000 • F: 321.637.1600

